

1. (10 pts) **We're going to play Final (exam) Jeopardy!** Associate the following answers with the appropriate question. (You are given the "answers": Pick the "question" that goes best with each "answer".) The first one has been done for you.

"Answers:"

- z. Anywhere but here. **v**
- 1a. A type of memory that uses capacitors to store data.
- 1b. A binary digit appended to a group of binary digits to make the sum of all the digits either always odd or always even.
- 1c. To maximize the efficient use of an expensive system.
- 1d. To make Memory appear to cost as much as the cheapest element and perform as well as the fastest element.
- 1e. Memory that goes away when the power is turned off.
- 1f. To relieve the need for the entire page table to be in memory.
- 1g. A technique used in CD-ROM Drives to increase storage density.
- 1h. A technique in which an I/O device is periodically checked to see if it needs service.
- 1i. A structure that holds recent mappings of virtual to physical addresses.
- 1j. A Flip Flop.

"Questions:"

- a) What is synchronous timing?
- b) What is asynchronous timing?
- c) What is a circuit that exhibits purely sequential behavior?
- d) What is the Data Bus?
- e) What is a Parity bit?
- f) What is a Register?
- g) What is a Cache?
- h) What is DMA?
- i) What is an Address Translation Lookaside Buffer (or TLB)?
- j) What is an interrupt?
- k) What is the goal of the Memory Hierarchy?
- l) What is a Page?
- m) What's the point to using a Base Page Table?
- n) What is Volatile memory?
- o) What is a Page Fault?
- p) What is Non-Volatile memory?
- q) What is polling?
- r) What is Constant Linear Velocity?
- s) What is Constant Angular Velocity?
- t) What is the goal of multiprogramming?
- u) What is Dynamic RAM?
- v) Where would I rather be right now than where I am?

9. (6) Given a logical 24-bit address and a 1Meg (1024K)-byte physical memory for a byte-addressable machine,

How big is the physical address space?

How big is the virtual address space?

Assuming 64K-byte pages, how many page frames are there? How many pages?

Assuming 1K-byte pages, how many page frames are there? How many pages?

10. (10 pts) Here is a 12-bit Error Correction code format (same one used in class):

$$d_8 \ d_7 \ d_6 \ d_5 \ C_4 \ d_4 \ d_3 \ d_2 \ C_3 \ d_1 \ C_2 \ C_1$$

- a. Given the *data* bit pattern

0 0 1 1 1 1 0 0

in a machine using the above ECC code, what bit pattern gets sent to memory? (No credit will be given without work being shown.)

- b. In this same machine, the following bit pattern is retrieved from memory:

0 1 1 1 1 0 0 0 0 0 0

Assuming the above Error Correction code format, identify and correct any errors that may have occurred during transmission or storage. (No credit will be given without work being shown.)

11. (10 pts) What is the maximum clock frequency possible for the following circuit? (In other words, what is the maximum clock frequency that will still guarantee correct behavior?) Use the following delay values, and assume all input signals become valid at time 0:

AND: 3ns NAND: 7ns NOT: 1ns MUX: 5ns Tprop: 6ns Tsetup: 3ns Thold: 1ns

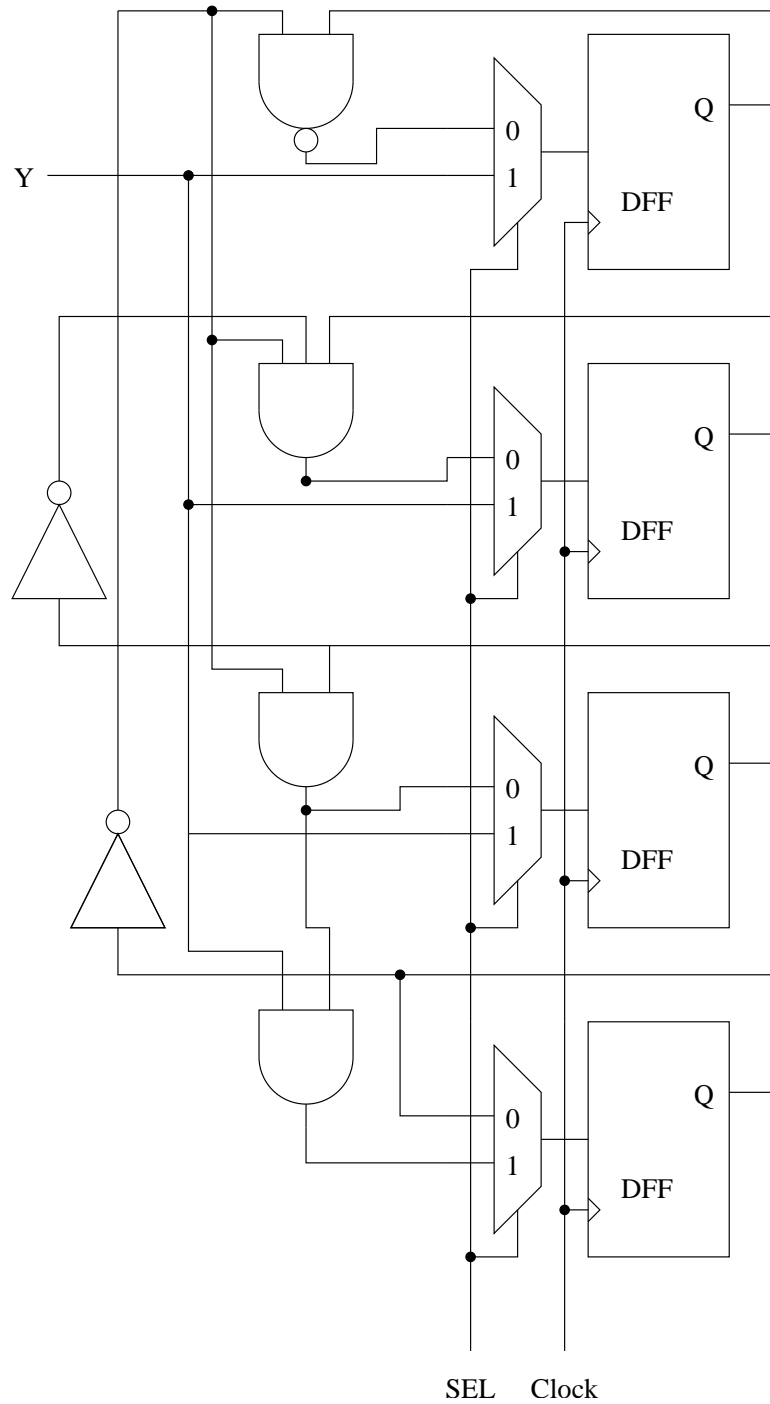

12. (5 pts) Add arrows to the following diagram to indicate which signal transitions **cause** other transitions to occur.

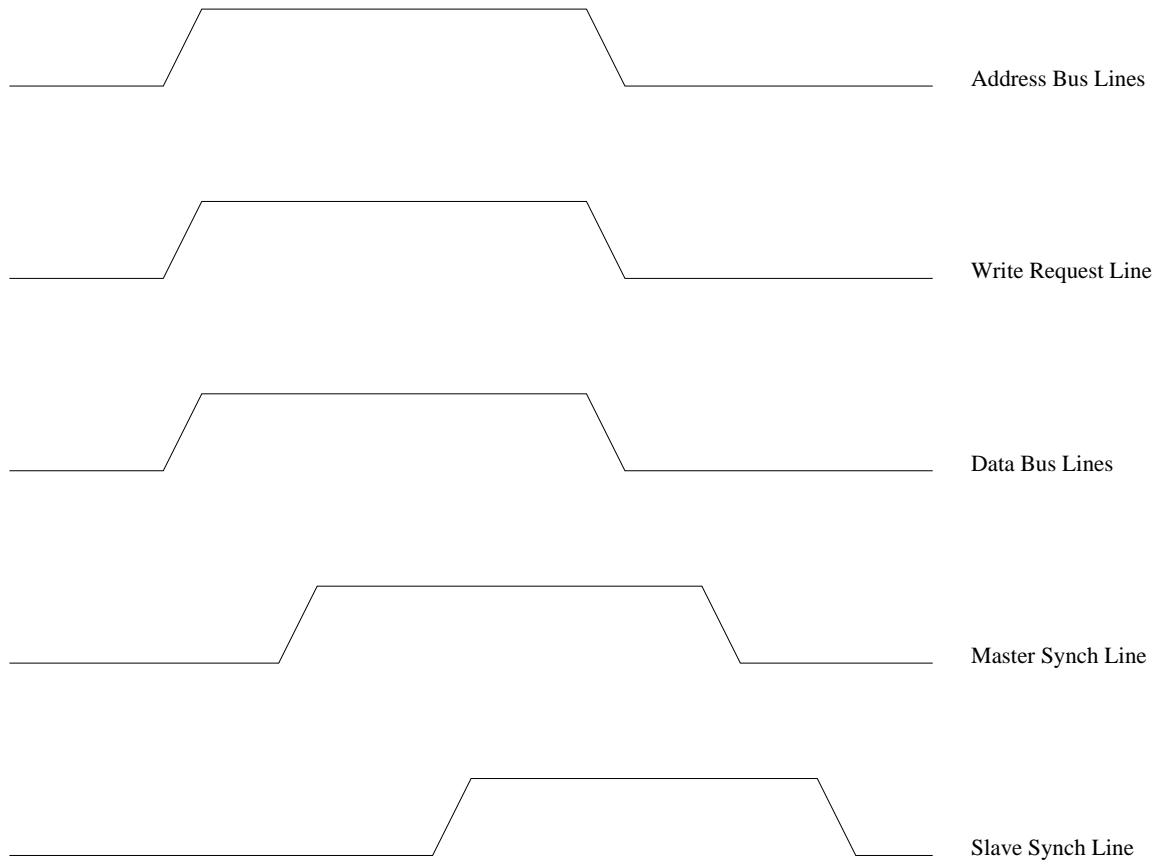

Now explain in words (briefly) what the arrows you have added are doing. (What is the sequence of events in words?)

13. (10 pts) Add the connections to the following diagram necessary to create a 24Kx8 memory. (This might be done in a machine with memory-mapped I/O, for example.) Not all of the hardware shown is required to perform this task.

CS - Chip Select
 OE - Output Enable
 RD - Read (Read/Write, technically)

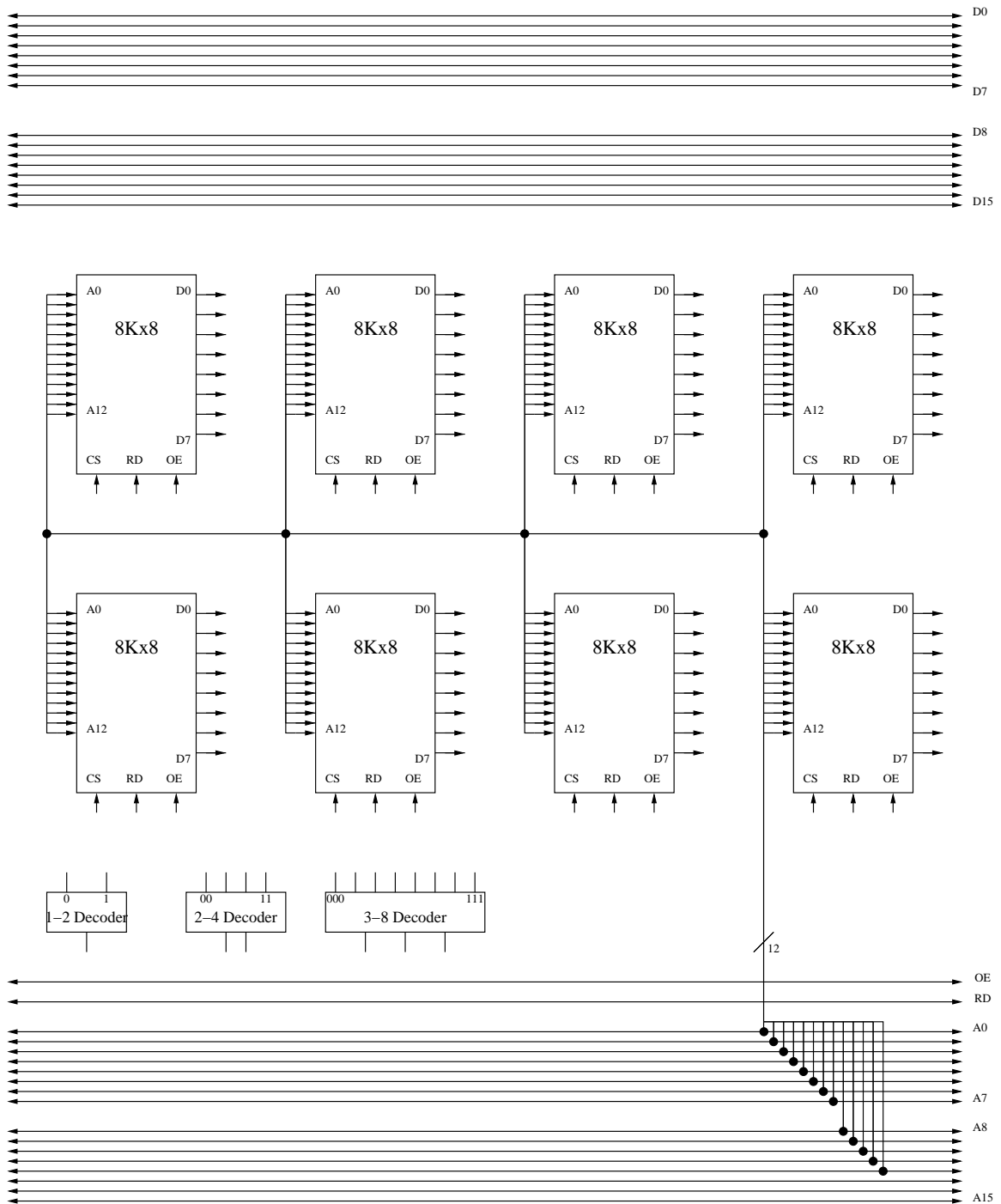

14. (15) Dill Computer features the "Pickle", a byte-addressable computer with a 32-bit word size and 256 bytes of memory. In this machine accessing main memory takes 7 clock cycles (in addition to the time necessary to do a cache lookup), and the bus between main memory and the processor is 8-bits wide. In order to improve performance, they are considering adding a 32-byte physically addressed Direct-Mapped cache with a line size of 2 words and an access time of 1 cycle. Given the following address reference sequence (in Hex):

0x35,0x36,0x37,0xC3,0x34

a) Write down how you are partitioning each address (which bits are the Tag, offset, etc.)

b) In the table below, fill in the proposed Cache's Tag values after each memory reference has been processed. If it is a hit, mark the entry number to indicate this, and if it is a miss enter what the new tag should be. (X indicates the entry is invalid). There may be more Tag Array entries than you need.

Tag Array	Contents of Tag Array after processing address (Time ->)					
Entry Number	Initial Contents	0x35 (00110101)	0x36 (00110110)	0x37 (00110111)	0xC3 (11000011)	0x34 (00110100)
0	X					
1	X					
2	X					
3	X					
4	X					
5	X					
6	X					
7	X					
8	X					
9	X					
10	X					
11	X					
12	X					
13	X					
14	X					
15	X					

What is the Average Memory access time for this sequence of references?

Now fill in the contents of the Data array after processing the given address reference. Write down only the ones that change.

Data Array	Data Array Contents after processing address
Entry Number	0x35
0	
1	
2	
3	
4	
5	
6	
7	
8	
9	
10	
11	
12	
13	
14	
15	

Memory Contents at Hex Address XY																
Most Significant Digit (X)	Least Significant Digit (Y)															
	0	1	2	3	4	5	6	7	8	9	a	b	c	d	e	f
0	23	20	6d	61	74	74	27	73	20	67	76	69	65	77	20	73
1	68	65	6c	6c	20	73	63	72	69	70	74	0a	73	65	74	20
2	67	66	69	6c	65	20	3d	20	24	31	0a	09	65	63	68	6f
3	20	2d	6e	20	22	67	67	72	61	70	68	20	24	67	66	69
4	6c	65	2e	2e	2e	22	20	0a	09	65	63	68	6f	20	22	2e
5	73	70	20	32	22	20	3e	21	20	2f	74	6d	70	2f	74	65
6	6d	70	24	24	2e	6e	72	0a	09	65	63	68	6f	20	22	2e
7	70	6f	20	2b	30	2e	35	69	22	20	3e	3e	20	2f	74	6d
8	23	7b	92	08	22	41	85	32	69	73	11	35	97	54	31	48
9	88	73	48	72	98	21	42	85	62	65	90	84	31	56	55	83
a	43	64	84	36	59	3c	8a	95	3b	8f	0e	41	7a	40	2b	3c
b	4c	d4	c7	82	a0	38	f9	c6	29	a3	d0	9c	7d	41	2b	75
c	54	69	9c	3b	b0	2a	d9	3e	45	72	6e	f0	f9	3f	a0	0a
d	60	89	43	d8	c0	e7	49	76	59	21	2c	c8	a8	f2	87	43
e	76	8f	2e	a9	ff	38	ae	65	dd	cf	21	84	ce	e4	34	51
f	8a	65	30	2f	c9	3a	58	72	3e	a0	4f	38	96	47	21	80

15. (15) Dill decided to experiment with using a smaller, 24-byte 3-way Set Associative Cache (instead of the Direct-mapped Cache) with a line size of 1 word. Remember, the Pickle is a byte-addressable machine with a 32-bit word size, an 8-bit bus between processor and memory, and a Main Memory access time of 7 cycles (in addition to the time necessary to to a cache lookup). The Cache access time is still 1 cycle. Given the same address reference sequence (in Hex) as before:

0x35,0x36,0x37,0xC3,0x34

a) Write down how you are partitioning each address (which bits are the Tag, offset, etc.)

b) In the table below, fill in the proposed Cache's Tag values after each memory reference has been processed. If it is a hit, put an "H" in the tag field, and if it is a miss write down what the new tag should be. Use an LRU replacement scheme, and after each address is processed be sure to indicate the age of the references. There may be more entries than you need. MRU = Most Recently Used, LRU = Least Recently Used.

Tag Array				Contents of Tag Array after processing address (Time ->)									
Set #	Entry #	Initial contents		0x35 (00110101)		0x36 (00110110)		0x37 (00110111)		0xC3 (11000011)		0x34 (00110100)	
		Age	Tag	Age	Tag	Age	Tag	Age	Tag	Age	Tag	Age	Tag
0	0	MRU	01100										
	1	LRU	01110										
	2		11000										
1	0		00100										
	1	MRU	00001										
	2	LRU	01101										
2	0	LRU	00100										
	1		01001										
	2	MRU	00110										
3	0	LRU	10010										
	1		00111										
	2	MRU	10110										

What is the Average Memory access time for this sequence of references?

16. (6 pts) The following tables contain some of the information about a segmented, paged virtual memory system and certain select memory locations. Total physical memory size is 16K bytes, and the page size is 512 bytes. All numbers in this table are in Hex unless otherwise noted.

Segment Table		
Entry Number	Presence Bit	Page Table
0	1	5
1	0	0
2	1	0
3	1	7
4	1	2
5	1	3
6	1	1
7	1	4

Page Table 0			
Entry Number	Present? (1=Yes)	Disk Addr	Frame Number
0	1	1234123	0x4
1	0	0893748	0x7
2	1	2489567	0x1
3	1	9623873	0x5
7	1	B0F6BD3	0x2
10	0	32829AA	0x1
12	1	56D87AC	0x0
15	1	10A876D	0x6

Page Table 2			
Entry Number	Present? (1=Yes)	Disk Addr	Frame Number
0	1	1234123	0x1
1	0	0893748	0x3
2	1	2489567	0x5
3	1	9623873	0x7
4	1	BC56BD3	0x9
5	0	832759E	0x2
11	1	46B37AC	0x4
15	1	810476D	0x6

Memory	
Address	Contents
0x00A4	0x76
0x01A4	0x73
0x02A4	0x32
0x03A4	0x46
0x14A4	0x30
0x2AA4	0x29
0x05A4	0xa9
0x09A4	0x74
0x1AA4	0x05
0x0CA4	0x23
0x0DA4	0xE3
0x17A4	0xAE
0x26A4	0x92

Page Table 5			
Entry Number	Present? (1=Yes)	Disk Addr	Frame Number
0	1	1234123	0x2
1	0	0893748	0x3
5	0	2489567	0x4
7	1	9623873	0x4
11	1	AE76BD3	0x6
13	0	328759A	0x7
14	1	11D87BE	0x1
15	1	91C875D	0x2

Page Table 7			
Entry Number	Present? (1=Yes)	Disk Addr	Frame Number
0	1	1234123	0x5
1	0	0893748	0x6
2	1	2489567	0x1
3	1	9623873	0x2
4	1	AE76BD3	0x4
5	0	328759A	0x2
6	1	56D87AC	0x5
7	1	10A876D	0x6

For each of the following convert the virtual address into a physical address (if possible) and write down the value of the memory location corresponding to the address. If it is not possible to do so, explain why.

0x82A4 (1 0 0 0 0 1 0 1 0 1 0 0 1 0 0 in binary).

0x5EA4 (0 1 0 1 1 1 1 0 1 0 1 0 0 1 0 0 in binary).

0x28A4 (0 0 1 0 1 0 0 0 1 0 1 0 0 1 0 0 in binary).

17. (16) Given the following table, draw the Karnaugh maps for $Y1'$, $Y2'$, and $Y3'$ and Z in terms of X, Y1, Y2 and Y3, and then write **minimum** boolean equations for each.

Present State (Y1 Y2 Y3)	Next State		Output	
	X=0 (Y1' Y2' Y3')	X=1 (Y1' Y2' Y3')	X=0	X=1
001	111	011	0	0
010	101	001	0	0
011	100	001	0	1
100	001	001	0	1
101	001	001	1	1
110	100	001	0	0
111	100	001	1	1

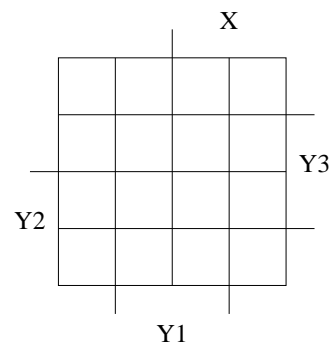
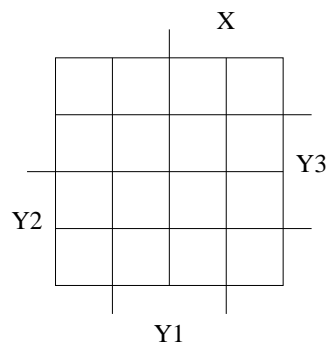
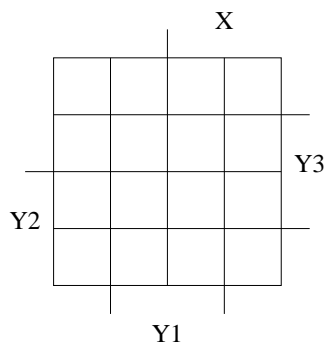
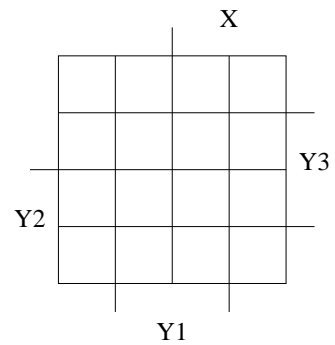
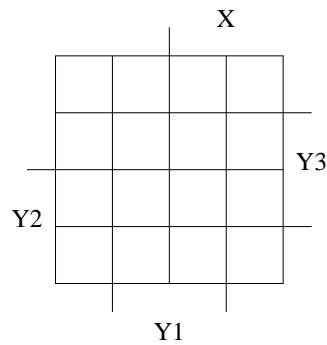
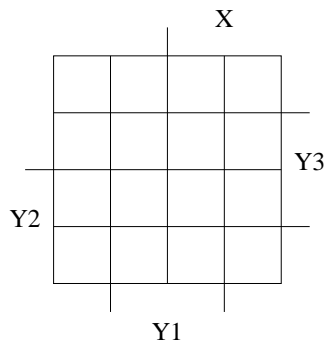

18. (15 pts) Given the following Karnaugh maps, implement the sequential machine using a JK FF for Y1, an SR FF for Y2, and a T FF for Y3. You do not need to draw the gates, but you do need to write down the **minimized** input equations for each of the inputs of each of the Flip Flops in the circuit.

